



# Harmony FE

Homelift

**Terry**  
total lift solutions

The Homelift Specialists  
Trusted for over 50 years

Buy direct from the British manufacturer

[www.terrylifts.co.uk/harmonyfe](http://www.terrylifts.co.uk/harmonyfe)  
Call **0330 053 6779** for free and impartial advice



Harmony FE Standard



## *Stay* IN YOUR HOME

**The Harmony FE (Fully Enclosed) Home Lift makes your life easier when stairs become too much.**

Why go through the stress and upheaval of moving house? A Terry Lifts 'through the floor' Home Lift allows you to regain the freedom of your home, while keeping your staircase clear.

It moves between floors smoothly and quietly, allowing you to travel safely and comfortably.

This 'through the floor' Home Lift requires much less space than a conventional lift. There is no shaft or structure required and the footprint of the lift is so compact that it can be placed almost anywhere in your home.

# *comfortable* AND EASY TO USE

Why the Harmony FE Homelift makes independent living a breeze.



Easy-to-use adjustable wireless controls come as standard in the cabin and at both floors.



Low cabin floor construction ensures easy wheelchair access and egress.



A simple push of the button sends the lift up. The controls can be positioned to suit your needs.



The aperture ceiling panel is automatically lifted or replaced en-route.



The lift moves to the other floor and vacates the space it was in.



The lift can be sent back to the floor below, leaving a feeling of space in the room.

# features

## Standard features

- ✓ Powered door
- ✓ Door open button on the external side of the lift cabin
- ✓ Easy to use adjustable wireless cabin controls
- ✓ Gloss white exterior and interior trims
- ✓ Full height glazed door
- ✓ Glass vision side panels
- ✓ Light grey carpet covered interior panels
- ✓ Four dimmable LED lights
- ✓ Telephone
- ✓ Charcoal carpeted floor
- ✓ Wireless call stations on both landings
- ✓ Wireless smoke/heat alarm
- ✓ Emergency lowering system
- ✓ 325 kg (51 stone) capacity
- ✓ 1 year parts and labour warranty

## Cabin details

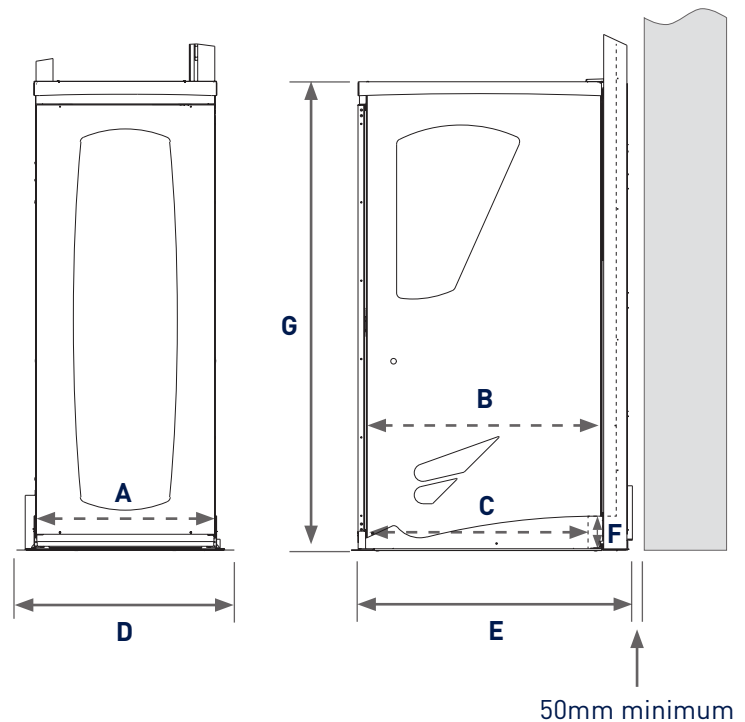

## Optional extras

- Upholstered fold up standard seat
- Joystick cabin control
- Hand-held remote control
- Radio isolation fob
- Handrail
- Grab points
- Mirror
- LED cabin side lighting
- Extended warranties including service visits

## Optional finishes

- Choice of carpet colour
- Cabin available in alternative RAL colours

Lift model	A Internal width	B Internal length above axle cover	C Internal length to axle cover	D External width	E External length	F Axle cover height	G Cabin height	Travel	Capacity
Harmony FE C (Compact)	745	826	726	910	914	90	2160	2400-3600	325 kg
Harmony FE S (Standard wheelchair)	745	1148	1045	910	1235	90	2160	2400-3600	325 kg
Harmony FE L (Wheelchair + attendant)	745	1348	1245	910	1435	90	2160	2400-3600	325 kg
Harmony FE LW (Wheelchair + attendant)	880	1348	1245	1045	1435	90	2160	2400-3600	325 kg



Harmony FE Standard

# *peace* OF MIND



**The safety of you and your family is our priority. This is why the Harmony FE Home Lift is equipped with all the essential safety features as standard.**

Pressure sensitive safety surfaces stop the lift if it is obstructed from above or below. The lift also features a battery back-up system, allowing you to return to the ground floor safely in the event of a power failure.

Fire safety is an important consideration. The Harmony FE Home Lift maintains fire and smoke protection between the floors, whether it is parked upstairs or downstairs. Smoke and heat alarms ensure the lift performs correctly in case of activation.

## THE TERRY LIFTS *guarantee*

**We guarantee the quality and safety of your home lift.**

- ✓ Pressure sensitive surfaces and safe edges
- ✓ Emergency lowering in case of power cuts
- ✓ 30-minute fire and smoke integrity maintained between floors
- ✓ Smoke/heat alarms provided on both floors helping to ensure your safety
- ✓ Fully enclosed cabin providing you with additional protection and peace of mind
- ✓ Complies with the 2006/42/EC Machinery Directive (CE mark)



# Stay IN YOUR HOME

## We will take care of everything

Purchasing and having your home lift installed is far less complicated than you might think.

We will survey your home and provide you with a written quotation. After your decision to proceed, we will first carry out all the necessary work. The installation itself takes less than two days.

## FREQUENTLY ASKED

## questions

**Is it possible to get stuck in a Harmony FE when I am on my own?** No. If there is a power cut at your property, then the battery backup and the manual lowering system operated from inside or outside the lift cabin will enable you to travel down to the ground floor. There is also a hard wired telephone fitted as standard, providing additional peace of mind.

**Can I use my wheelchair in a Harmony FE?** Yes, we offer two wheelchair models, the standard and the longer-wider. Terry Lifts designed the Harmony FE **standard** model in collaboration with our customers to meet the requirements of a sole wheelchair user and the **longer-wider** model to accommodate an accompanying attendant. The **compact** model has a spacious cabin for one person seated or two people standing. Please refer to internal dimensions guide on page 4.

**Does Terry Lifts manage the building work?** Yes. We can complete all building work or alternatively, we can forward on the Specification Guide to your builder, the choice is yours. Normally, no major structural work is required.

**Why do you use a hydraulic lift pump?** The hydraulic pump powers the 'Quiet Glide System' providing very smooth, vibration free travel. Such a smooth ride would not be possible with a rope drive.

**How much space does a Harmony FE Lift take?** The three Harmony FE models are designed to minimise the external footprint and maximise the internal space for every need. The compact is the smallest. Please refer to the dimension guide on page 4.

**Is the Harmony FE Lift safe in the event of a fire?** It is fire and smoke test certificated by an approved and accredited test laboratory, together with Notified Body certification concerning compliance with BS5900:2012 in relation to through floor lifts. This covers fire safety for the Harmony FE Lift in both the lower and upper position.

**I plan to keep my lift for a very long time. Will Terry Lifts service and care for my lift?** Yes. A one year parts and labour warranty comes as standard. This can be extended up to 5 years. You can call our aftercare service team to discuss the options available.

**Can installing a Harmony FE Lift be cheaper than moving home?** Yes, almost certainly. We are often told by our customers that it was cheaper and less stressful than moving home. Call 0330 053 6779 for a free no obligation quote to help you decide.



Harmony FE Home Lift

If you haven't previously considered a home lift, speak directly to the manufacturer and join the many customers who are experiencing the convenience and reliability of a Terry Lift. Call **0330 053 6779** to ask any question, or to arrange a consultation.



Lifestyle Home Lift



Harmony Home Lift

# Terry

total lift solutions

Terry Group Ltd.  
Unit 1-3, Longridge Trading Estate  
Knutsford, Cheshire WA16 8PR

**Tel: +44 (0)330 053 6779**

**[www.terrylifts.co.uk](http://www.terrylifts.co.uk)**

**[enquiries@terrylifts.co.uk](mailto:enquiries@terrylifts.co.uk)**



Terry Lifts' policy is one of continuous product development and the company reserves the right to change specifications without notice.