

FOR STRAIGHT
STAIRCASES

HOME GLIDE

ACCESS



**THE HOMEGLIDE'S
ALUMINIUM RAIL
HAS A SLIM DESIGN
GIVING A MODERN
AND CLEAN LOOK.**

02

The HomeGlide stairlift range delivers a solution for all straight staircase requirements and budgets. The HomeGlide, HomeGlide Extra and HomeGlide Outdoor are fitted onto your staircase and not your wall. This allows the lift to be installed quickly, easily and with minimal disruption to your home.

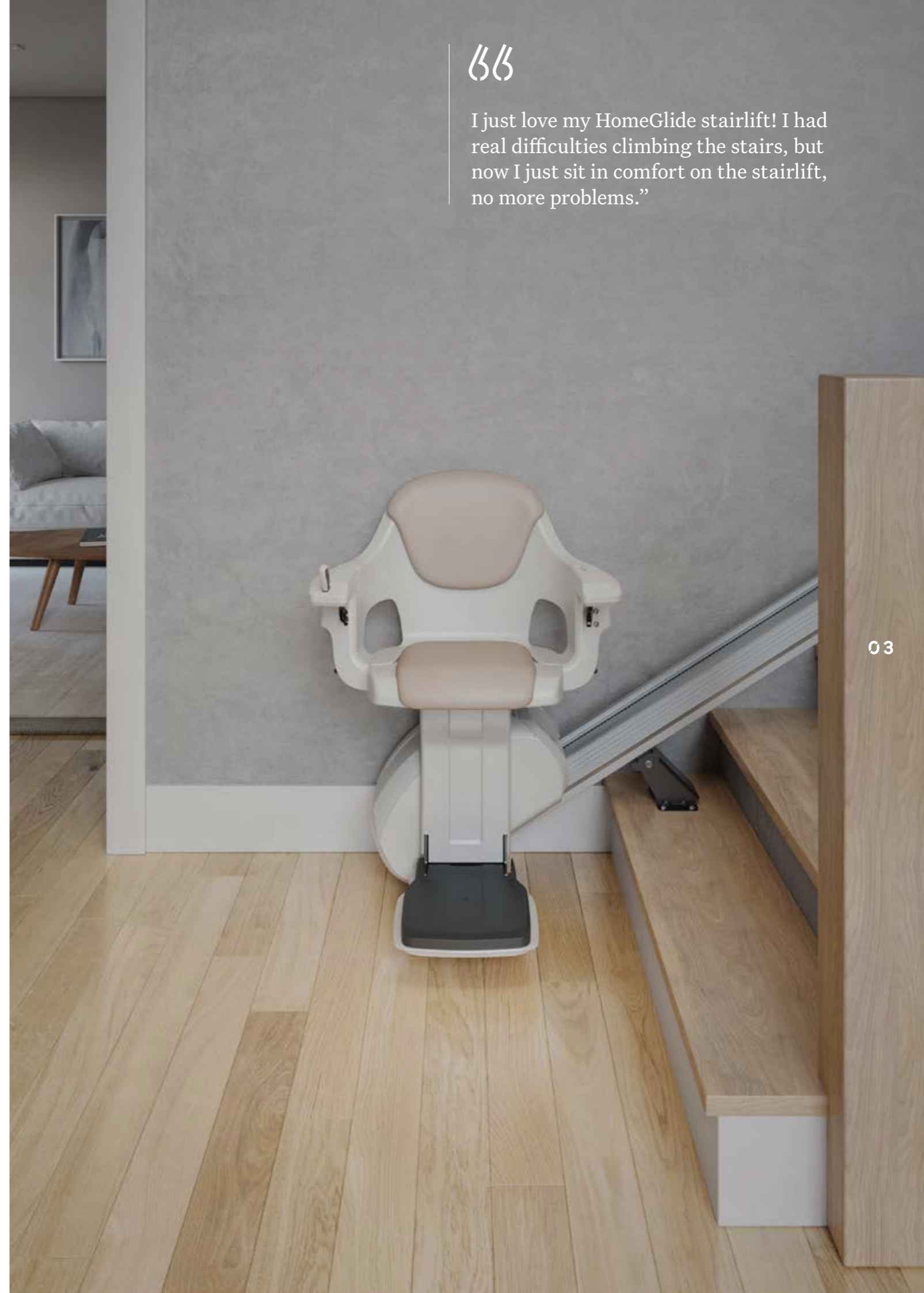

BB

I just love my HomeGlide stairlift! I had real difficulties climbing the stairs, but now I just sit in comfort on the stairlift, no more problems.”

03

1

IT'S ALL ABOUT YOU

The thick and luxurious padding ensures a firm and comfortable seat. The sisal colour of the upholstery is a neutral tone which will fit in every household. The upholstery is also fire retardant, liquid repellent and easy to clean. The HomeGlide is operated with an easy to use joystick which can also be removed to prevent unauthorised usage.



It is designed to glide effortlessly along an aluminium track, providing an attractive, elegant and discreet addition to your home. Built using the latest technology, the HomeGlide stairlift range can be fitted to almost all straight staircases as narrow as 740mm.

2

COMPACT AND DISCREET

04

The HomeGlide's design is simple, sturdy and above all satisfies your accessibility requirements. Remote control handsets allow the HomeGlide to park at either the top or bottom of the staircase, wherever is the most convenient for you. When not in use the HomeGlide is folded away to only 380mm on any landing, out of the way of any other staircase users.

3

SAFETY

Your safety is of paramount importance to us. The HomeGlide stairlift is certified to machine directive 2006/42/EG and BS EN 81-40. During travel the retractable seat belt will keep you secure on the stairlift. If the lift encounters an obstacle it will safely come to a stop as a result of special safety edges on the drive unit. The stairlift is battery operated, which means you can still use it during a power cut.

2



1

3



05

MOVE BETWEEN ALL LEVELS OF YOUR HOME WITH MAXIMUM COMFORT AND SAFETY.

OPTIONS

06

IT'S ALL ABOUT YOU

When you choose a HomeGlide stairlift you ensure an ideal solution for your staircase. With a smooth aluminium track, this stairlift can be fitted to almost any straight staircase.



Automatic Powered Hinge

If you have an obstruction at the foot of the staircase you can choose to have an automatic powered hinge installed. Once you have used the stairlift it will return to the top of the stairs and the lower section of the rail will fold away, leaving the bottom of your staircase clear.



Retractable Safety Belt

A retractable seat belt keeps you secure while using your HomeGlide stairlift.

07

HOMEGLIDE EXTRA

08 AN ARRAY OF
OPTIONS AND
ENHANCEMENTS

With an added choice of upholstery and functionality options, HomeGlide Extra is an elegant and attractive addition to your home.

UPHOLSTERY

Vinyl



Red



Grey



Maroon



Sisal

Fabric



Dark Brown

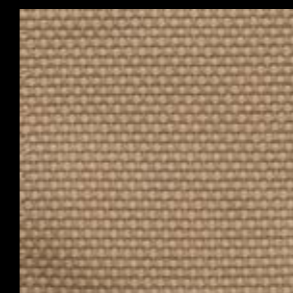

Beige

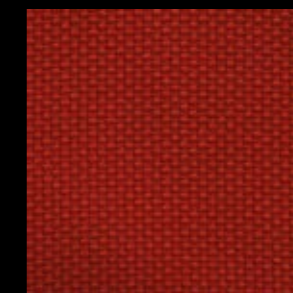

Red

09

CHOOSE FROM
FABRIC AND VINYL
SEAT COVERS TO
MATCH THE STYLE
OF YOUR HOME.

1

Linked footrest

As standard, the HomeGlide Extra comes with a linked footrest. This feature makes it most effortless when unfolding the chair as the footrest is linked to the seat.

2

Ergonomically-shaped seat

Designed with ergonomic experts the HomeGlide Extra uses a seat which positively influences your posture while offering maximum comfort.

There are four different seat heights to choose from providing you with the most comfortable seating position possible.

3

A world of choice

As well as the quality enhancements that come as standard with the HomeGlide Extra, there are a number of options available which include a wide array of upholstery colours. Choose from fabric and vinyl seat covers to match the style of your home and décor.

4

Powered swivel seat

The HomeGlide Extra comes with a manual swivel seat as standard. Upgrading to the powered swivel seat allows you to turn the chair easily at the top or bottom landing by maintaining pressure on the joystick. This allows a safe exit from the chair as the lift automatically rotates away from the open staircase.

AS STANDARD, THE HOMEGLIDE EXTRA COMES WITH A LINKED FOOTREST.





HOMEGLIDE OUTDOOR ACCESS ALL YEAR ROUND

**WITH THE IP-55
RATED HOMEGLIDE
OUTDOOR MODEL,
YOU CAN ENJOY
OUTDOOR ACCESS
WHATEVER THE
WEATHER.**



The HomeGlide Outdoor has successfully passed a range of industry accepted corrosion, rain protection and climate testing to ensure reliability and performance, and has specially treated components to provide you with a stairlift that can be used at any time of the year.



A weatherproof coating on all exposed parts of the lift protects against rain, dust and direct sunlight. A cover is provided to give additional protection to the lift when not in use.

TECHNICAL SPECIFICATION

CERTIFIED TO THE HIGHEST STANDARDS

SPECIFICATION

Speed	Max 0.12 m/s
Drive Type	Rack and pinion
Motor Wattage	280 W
Weight Capacity	Standard: max 125 kg Optional: max 146 kg
Batteries	2 × 12 V batteries; total 24V
Operation	Joystick control as standard
Staircase Incline	28° up to 53° (28° up to 45° with 146 kg option)
Certification	Machine Directive 2006/42/EG BS EN 81-40
Automatic Stop	Yes
Footrest	Yes
Retractable Safety Belt	Yes

“

The HomeGlide is the perfect solution for any straight staircase. I was able to install the stairlift within just a few hours – the customer was delighted.”

14

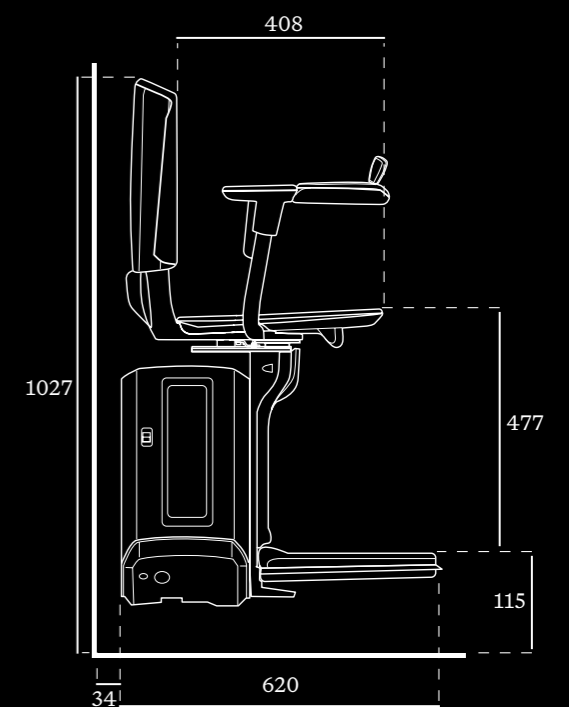
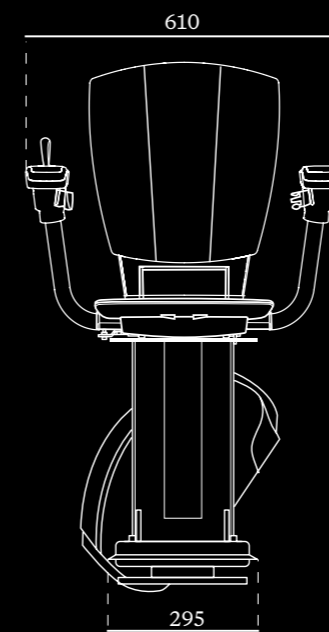
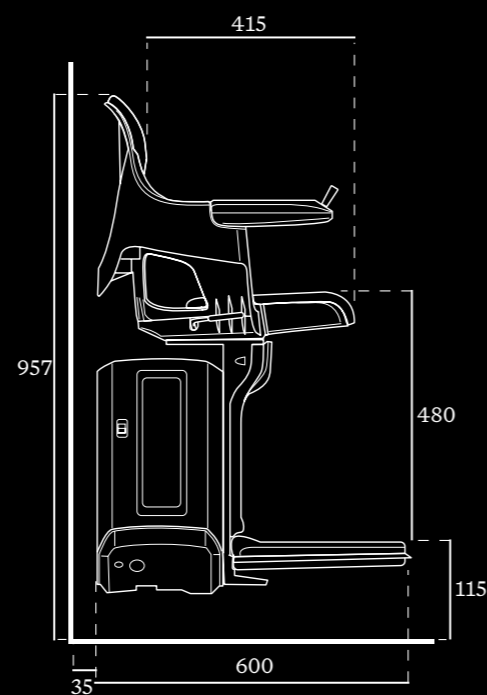
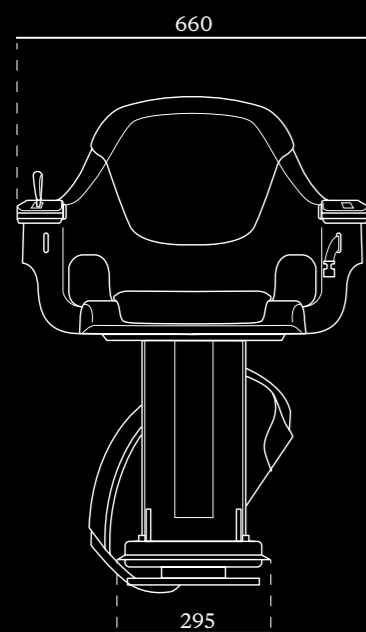

15

THE HOMEGlide
EXTRA PROVES TO
BE THE ULTIMATE
MARRIAGE OF
ELEGANT DESIGN
AND HI-TECH
FUNCTIONALITY
FOR ANY STRAIGHT
STAIRCASE.



ABOUT ACCESS

18

Access BDD is a division of thyssenkrupp Access Ltd. We give people around the world the ability to move comfortably around buildings by providing stairlifts, platform lifts and home lifts, which we distribute via a network of carefully chosen business partners. When you choose an Access BDD lift, you're choosing a high-quality product, supported by expert service and advice.

Our partners are all specialists in mobility or elevator products, and they receive extensive technical and commercial training on our products. Your Access BDD partner will guide you through the product options to help you choose a lift that meets your own needs and suits your surroundings. You'll also receive expert advice to ensure that your new lift conforms to relevant accessibility and safety regulations.

Our products are designed for easy installation and maintenance, with everything taken care of by your Access BDD approved partner.



19

**SINCE 1976 WE'VE
BEEN SIMPLIFYING
COMPLEX CHOICES
TO HELP PEOPLE
MOVE AROUND
THEIR HOMES.**

Access BDD is one of Europe's leading suppliers of stairlifts, platform lifts and home lift solutions.

Your local Access BDD dealer is:

