

FOR STRAIGHT
AND CURVED
STAIRCASES

FLOW 2

ACCESS



**THE FLOW2 SINGLE
RAIL STAIRLIFT
IS THE MARKET
LEADER WHEN IT
COMES TO CURVED
STAIRLIFTS AND
IS THE SMARTEST
LIFT OF ITS TYPE**

02

The award-winning Flow2 stairlift can be truly considered one of the world's leading stairlifts. The Flow2 is fitted onto your staircase and not your wall allowing the lift to be installed quickly, easily and with minimal disruption to your home.

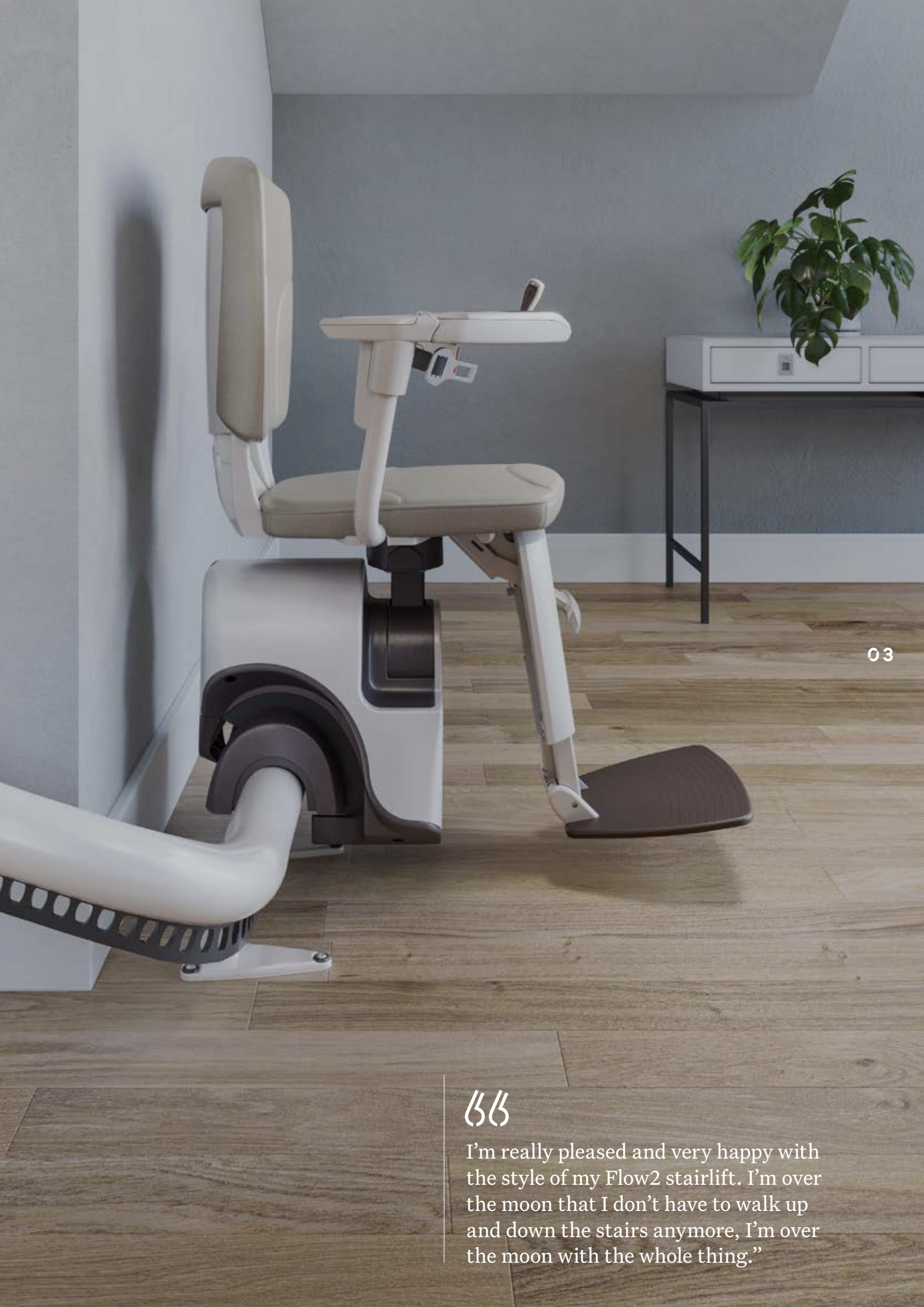

”

I'm really pleased and very happy with the style of my Flow2 stairlift. I'm over the moon that I don't have to walk up and down the stairs anymore, I'm over the moon with the whole thing.”

1

IT'S ALL ABOUT YOU

Designed with you in mind, the Flow2 has an ergonomically-shaped seat which provides you with an enjoyable and comfortable ride. The Flow2 is available in a number of finishes and colour options that allow you to match it to the style of your home. Choose from fabric, vinyl and leather seat covers and a range of different rail colours.

2

COMPACT AND DISCREET

When not in use the Flow2 is folded away to only 340 mm on any landing, out of the way of other staircase users. The Flow2 has a single discreet rail that closely follows the line of your stairs and can be fitted on either side of your staircase.

2



04

3

SAFETY

Your safety is of paramount importance to us. The Flow2 stairlift is certified to machine directive 2006/42/EG and BS EN 81-40. The seat is adjusted in height so you can get on and off safely at the top or bottom landing. During travel the seat belt and optional wrap-around armrests keep you secure on the stairlift.

3



Manufactured using the very latest technology, the Flow2 can be installed on nearly any type of staircase. The automatic swivel and levelling technology (ASL) allows the Flow2 to be fitted on staircases as narrow as 610 mm. This feature, unique to the Flow2, enables your stairlift to turn while in motion, making it one of the most adaptable stairlifts in the world.





ASL

ADVANCED

06 SWIVEL AND

LEVELLING

TECHNOLOGY

ASL technology enables the Flow2 stairlift to rotate and stay perfectly level while in motion. By rotating during travel, you're always in the safest and most comfortable position.



1

The seat is always in the correct position to get on and off safely

The Flow2 swivels as it travels, this means that getting on and off the lift at either end of the staircase is quick and easy. At the top of the staircase the seat can rotate away from the open staircase, allowing a safe exit from the seat.

2

Constantly working to save you time and provide safety and comfort

ASL technology operates while the lift is moving. Therefore you avoid additional stops and swivel movements at the beginning, during and at the end of the ride. This saves time and provides additional safety and comfort. The lift really moves in one "Flow".

3

Internal or external rail on the narrowest and steepest stairs

Even in cases where the staircase is narrow and steep, the Flow2 can be installed closer to the step and on either side of the staircase. Your stairlift will be less obtrusive and your staircase remains accessible for other family members in your home.

4

Unique technology that can only be found with the Flow2

Your well-being is important to us – when you choose ASL technology the footrest swivels with the seat ensuring your legs and feet remain in a natural and comfortable position, relieving any additional strain on your joints.



**ASL TECHNOLOGY
ALLOWS THE RAIL
TO BE KEPT AS
LOW AS 62 MM ON
A WIDE VARIETY
OF STAIRCASE
STYLES AND
CONFIGURATIONS**

09



OPTIONS

10

IT'S ALL
ABOUT YOU

When you choose the Flow2 stairlift, you ensure the best fit for your staircase. With a single discreet rail, this stairlift can be tailor-made to fit any staircase.

RAIL



Standard Drop Nose

The standard drop nose is the perfect solution if there is an obstruction such as a door near to the bottom of the stairs. The drop nose requires just 175 mm of space from the bottom step.



Vertical 'Short-Start' Drop Nose

Where space is even tighter at the bottom the 'short-start' drop nose can be installed, needing only 100 mm of space from the bottom step.



Horizontal Overrun

Where you have extra space at the bottom of the stairs the horizontal overrun allows the chair to be parked away from the bottom step.



Parking Curve

A parking curve allows the chair to be parked neatly out of the way of the stairs.

COLOUR



Grey



White/Grey



Beige/Brown



Brown/Grey

UPHOLSTERY

Vinyl



Red



Grey



Maroon



Sisal

Fabric



Dark Brown



Beige



Red

12

Elegant Leather



Aubergine-Beige



Beige-Grey



Brown-Beige



Brown-Cognac



Brown-Grey



Red-Beige

Deluxe Leather



Beige



Dark Brown



Dark Red

ARMREST



Straight



Curved

13

JOYSTICK & CALL DEVICE



Joystick



Call Device

CALL & PARK

14

YOU'RE IN
CONTROL

Remote control units at the top and bottom of the stairs are used to call your lift and to send it to a parking point when not in use.





CARS

THE WALKER STORY TELLER
THE FALKNER BOOK
THE WALKER STORY TELLER

Finnish
Architecture
with an Edge

THE WALKER STORY TELLER
THE FALKNER BOOK
THE WALKER STORY TELLER

THE FLOW2
STAIRLIFT CAN
BE INSTALLED
ON STAIRCASES
AS NARROW AS
610 MM AND AS
STEEP AS 70°



TECHNICAL SPECIFICATION CERTIFIED TO THE HIGHEST STANDARDS

18

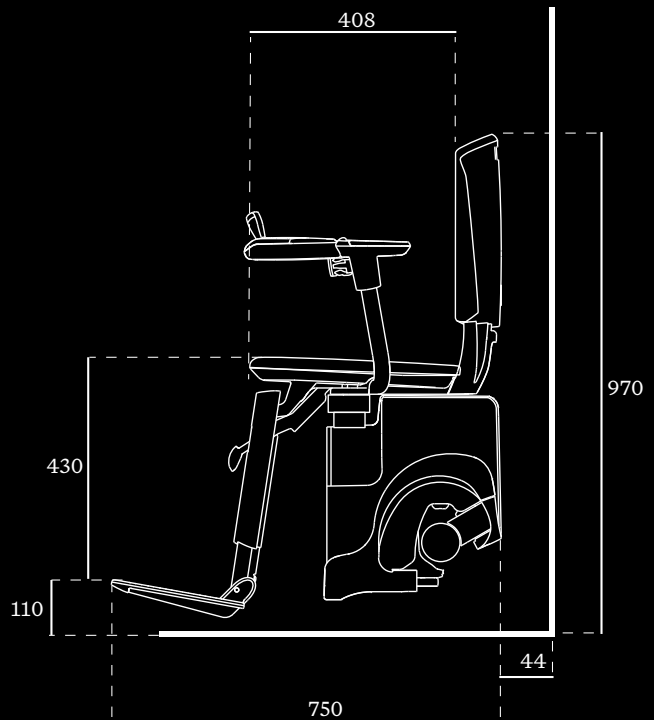
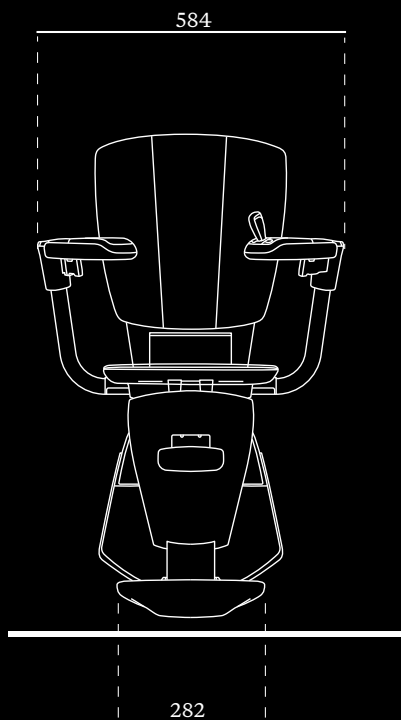

SPECIFICATION

Speed	Max 0.15 m/s
Drive Type	Rack and pinion
Motor Wattage	350 W – Drive Motor 350 W – Horizontal Motor
Weight Capacity	125 kg
Batteries	2 × 12 V batteries; total 24V
Operation	Joystick control as standard
Staircase Incline	Up to 70°
Certification	Machine Directive 2006/42/ EG BS EN 81-40
Automatic Stop	Yes
Footrest	Yes
Retractable Safety Belt	Yes

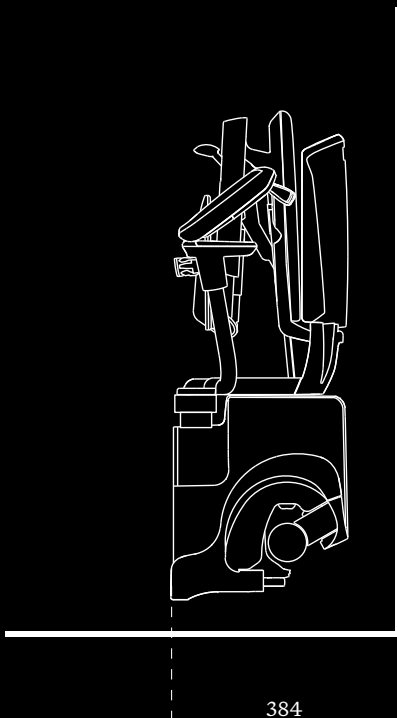

The Flow2 stairlift is one of the most reliable products I've had the pleasure of working with."



**YOUR STAIRCASE
REMAINS OPEN
AND ACCESSIBLE
FOR OTHER
FAMILY MEMBERS
IN YOUR HOME**

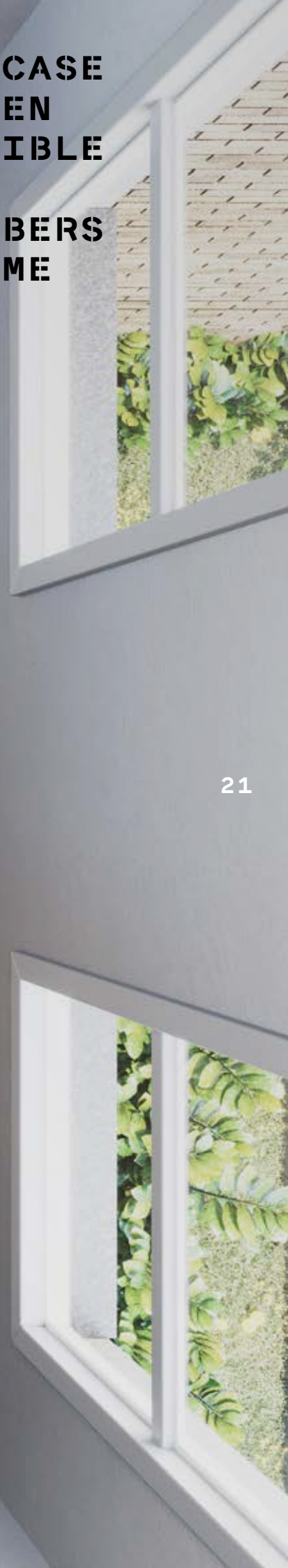

ABOUT ACCESS

22

Access BDD is a division of thyssenkrupp Access Ltd. We give people around the world the ability to move comfortably around buildings by providing stairlifts, platform lifts and home lifts, which we distribute via a network of carefully chosen business partners. When you choose an Access BDD lift, you're choosing a high-quality product, supported by expert service and advice.

Our partners are all specialists in mobility or elevator products, and they receive extensive technical and commercial training on our products. Your Access BDD partner will guide you through the product options to help you choose a lift that meets your own needs and suits your surroundings. You'll also receive expert advice to ensure that your new lift conforms to relevant accessibility and safety regulations.

Our products are designed for easy installation and maintenance, with everything taken care of by your Access BDD approved partner.





**SINCE 1976 WE'VE
BEEN SIMPLIFYING
COMPLEX CHOICES
TO HELP PEOPLE
MOVE AROUND
THEIR HOMES**

Access BDD is one of Europe's leading suppliers of stairlifts, platform lifts and home lift solutions

Your local Access BDD dealer is:

